

Where Have All
The Crayons Gone?

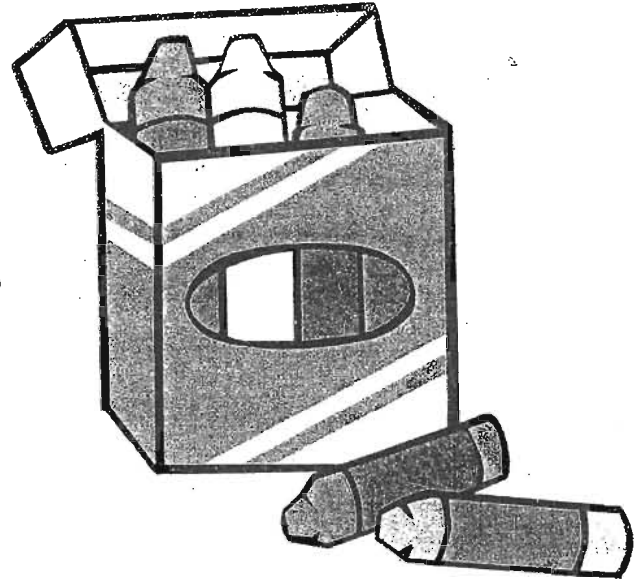

©TeachWithMe.com

Where Have All
The Crayons Gone?

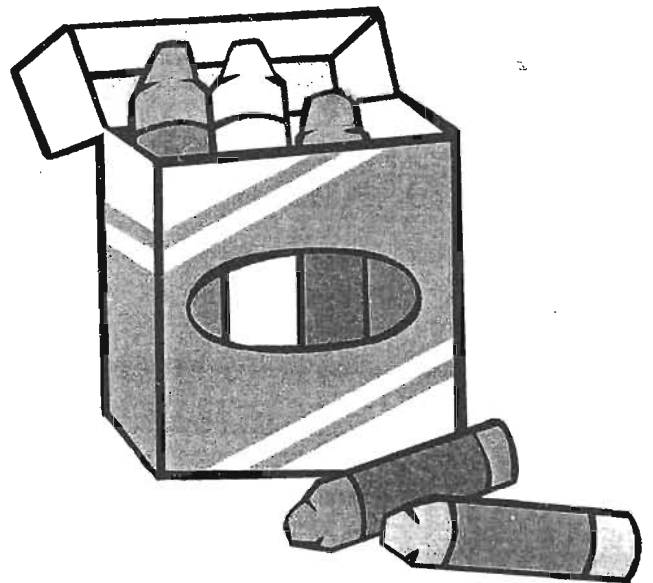

©TeachWithMe.com

$$5 - 1 = 4$$

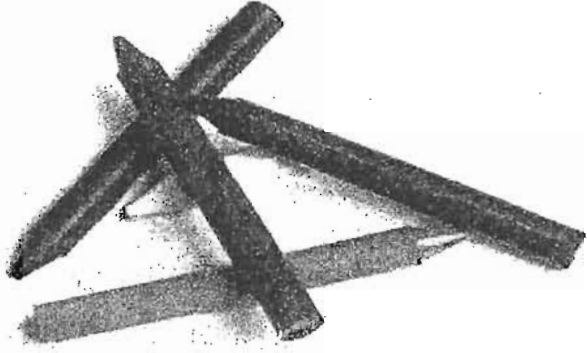

five

$$5 - 1 = 4$$

There were 5 crayons.

1 disappeared. That left 4.

$$5 - 1 = 4$$

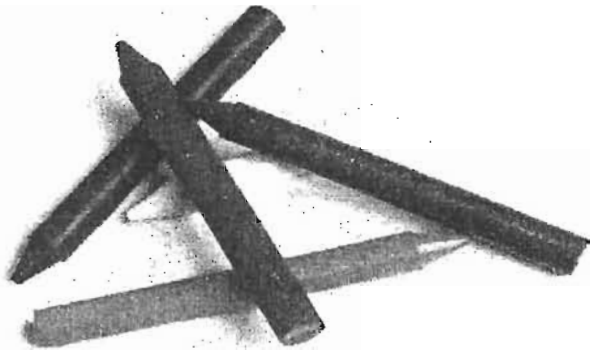

five

$$5 - 1 = 4$$

There were 5 crayons.

1 disappeared. That left 4.

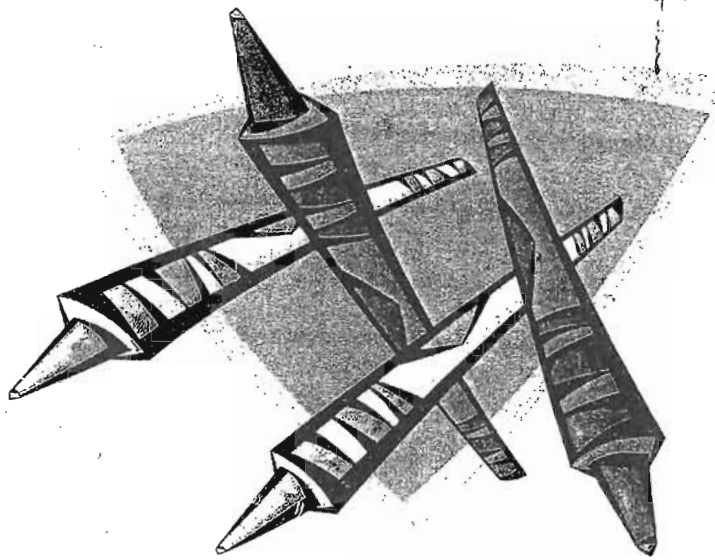

$$4 - 1 = 3$$

four

$$\begin{array}{r} 4 \\ - 1 \\ \hline \end{array}$$

There were 4 crayons.
1 disappeared. That left 3.

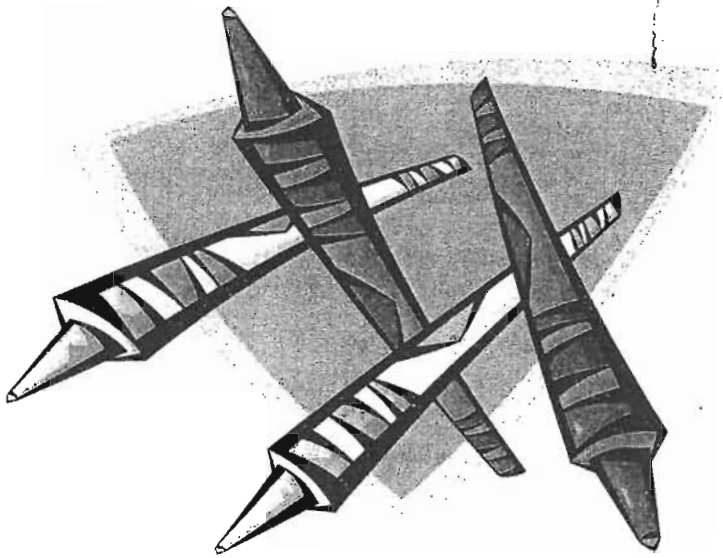

$$4 - 1 = 3$$

four

$$\begin{array}{r} 4 \\ - 1 \\ \hline \end{array}$$

There were 4 crayons.
1 disappeared. That left 3.

$$3 - 1 = 2$$

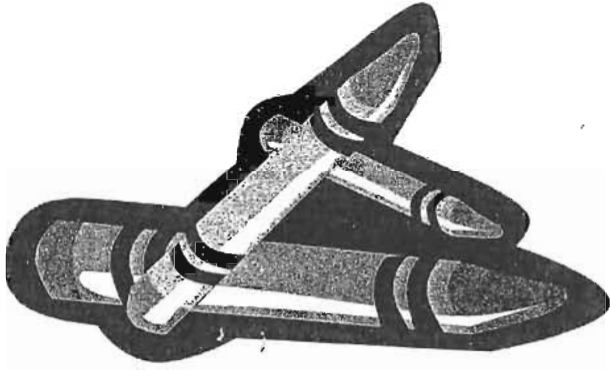

three

$$\begin{array}{r} 3 \\ - 1 \\ \hline \end{array}$$

There were 3 crayons.

1 disappeared. That left 2.

$$3 - 1 = 2$$

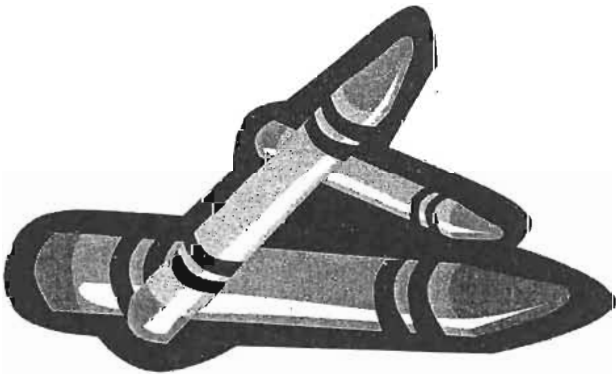

three

$$\begin{array}{r} 3 \\ - 1 \\ \hline \end{array}$$

There were 3 crayons.

1 disappeared. That left 2.

$$2 - 1 = 1$$

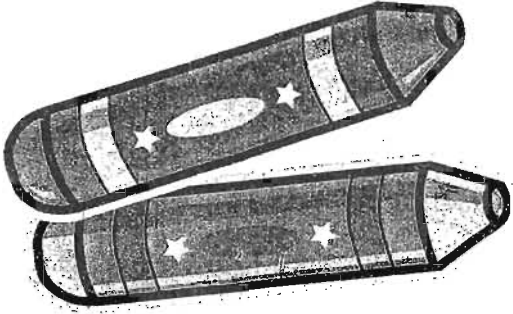

+ two

$$\begin{array}{r} 2 \\ - 1 \\ \hline 1 \end{array}$$

There were 2 crayons.
1 disappeared. That left 1.

$$2 - 1 = 1$$

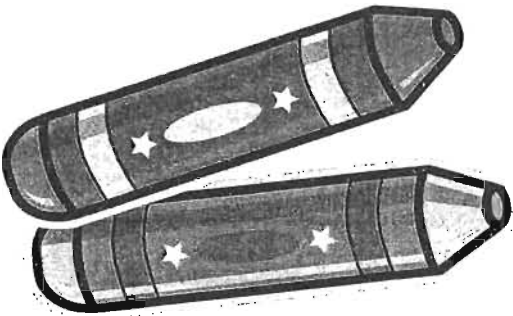

+ two

$$\begin{array}{r} 2 \\ - 1 \\ \hline 1 \end{array}$$

There were 2 crayons.
1 disappeared. That left 1.

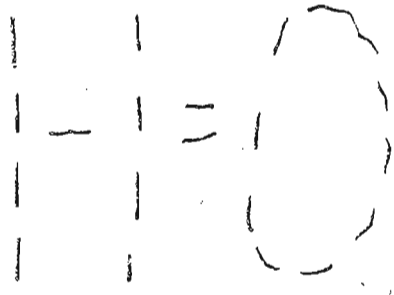
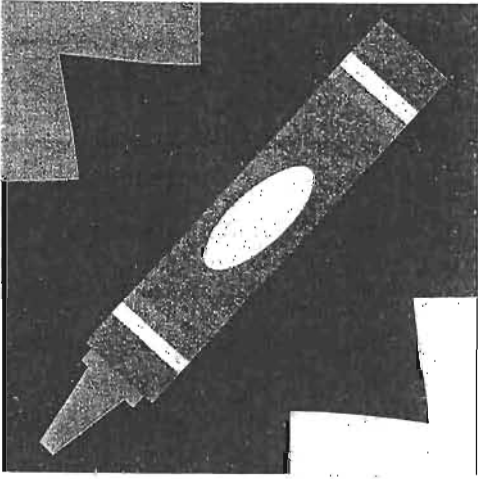

one

There was 1 crayon.
It disappeared. That left 0.
Where have all the crayons gone?

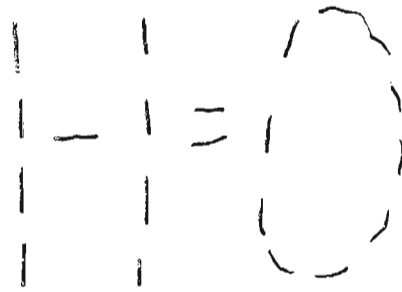
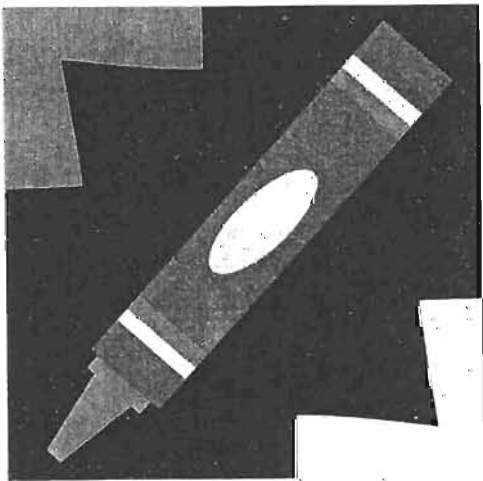

one

There was 1 crayon.
It disappeared. That left 0.
Where have all the crayons gone?

Back in their box.

It's September, and time for school!

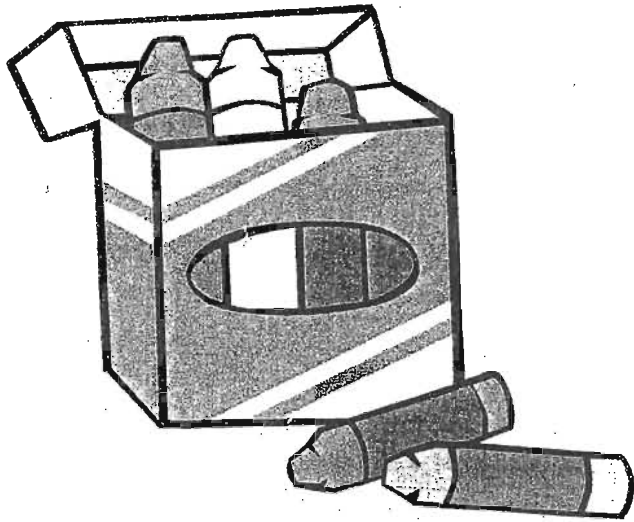

Back in their box.

It's September, and time for school!

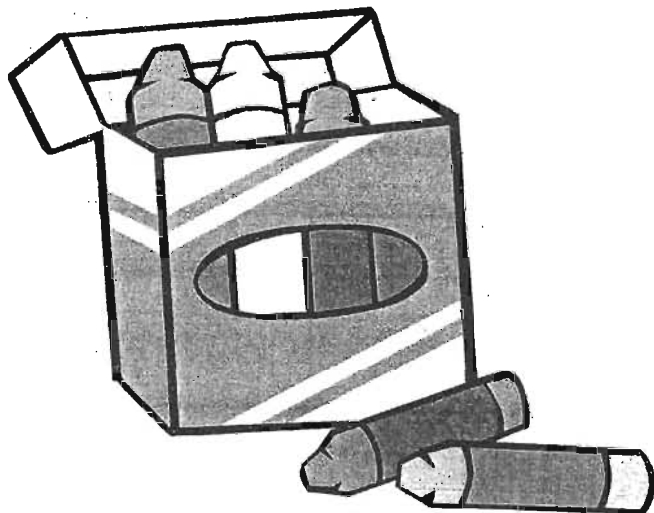

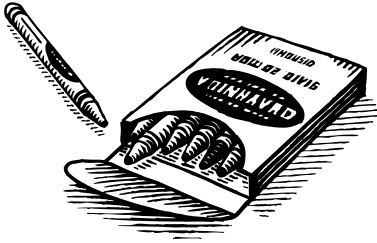

Discussion, Graphing & Writing Extensions For *Where Have All The Crayons Gone?*

Writing:

- Students write 5 “quick” endings of their own.
- Children share 1 or 2 of their endings with the class.

Discussion:

- Did you like the ending?
- Can you think of a better one?
- Where else could they have gone?

Math Extension:

- Teacher writes a list of the student’s ideas on the board.
- Choose three of the ideas + the book ending and **GRAPH** the favorite ending of the class.

Here are some of my new “Quick Endings”

1. They’ve been stolen by the Crayon Nappers and are being held for ransom.
2. They melted.
3. They got broken by bandits.
4. Nobody knows! Do you?
5. Ask the principal!

**Did your class come up with some cute and clever ones?
Please share with us and I’ll post them on the Blog! Thanks. 😊**